

True RMS

AUTO RANGE MULTIMETER

*CAT III-1000 V category, Auto range, REL, Capacitance
Hz, Duty, ACV, ACA, DCV, DCA, Ohms*

AM-1061 User's Manual



Caution Symbol

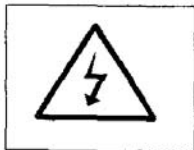

Caution :

- * Risk of electric shock !



Caution :

- * Do not apply the overload voltage, current to the input terminal !
- * Remove test leads before open the battery cover !
- * Cleaning - Only use the dry cloth to clean the plastic case !

Environment Conditions

- * *Installation Categories III-1000V.*
- * *Pollution Degree 2.*
- * *Altitude up to 2000 meters.*
- * *Indoor use.*
- * *Relative humidity 80% max.*

TABLE OF CONTENTS

1. FEATURES.....	1
2. SPECIFICATIONS.....	2
2-1 General Specifications.....	2
2-2 Electrical Specifications.....	3
3. FRONT PANEL DESCRIPTION.....	6
4. PRECAUTIONS & PREPARATIONS FOR MEASUREMENT.....	8
5. MEASURING PROCEDURE.....	9
5-1 Symbols & Units of Display	9
5-2 DC voltage, AC voltage Measurement	10
5-3 Resistance Measurement.....	10
5-4 DC current, AC current Measurement	11
5-5 Continuity Check	13
5-6 Diode Test	13
5-7 Capacitance Measurement.....	14
5-8 Frequency, DUTY Measurement.....	15
5-9 Relative Measurement.....	16
5-10 Data Hold Operation.....	16
6. MAINTENANCE.....	17
6-1 Replacement of Battery.....	17
6-2 Cleaning.....	17
6-3 Replacement of Fuse.....	18
7. OPTIONAL ACCESSORIES & ADAPTERS	19
8. THE ADDRESS OF AFTER SERVICE CENTER.....	20

1. FEATURES

- * True RMS ACV, ACA measurement
- * Meet IEC 1010 CAT III 1000 V safety requirement.
- * Large LCD display with measurement unit.
- * Multi function measurement. DCV, ACV, DCA, ACA, Resistance, Capacitance, Frequency, Duty, Diode, Continuity beeper.
- * Data hold.
- * Relative measurement.
- * Auto range with manual range selection.
- * When make the ACV, ACA measurement, it also can measure the signal frequency, % duty at the same time.
- * 4000 counts A/D, high resolution.
- * Both 10 A, mA, μ A current are build fuse for safety consideration.
- * 10 M ohm impedance for voltage circuit.
- * Operates from one DC 9V battery,
- * Built-in overload protection for most ranges.
- * Uses durable, long-lasting components, enclosed in strong, light weight ABS-plastic housing.
- * Full line optional adapters : Clamp adapter, Tachometer adapter, Pressure adapter, Humidity Adapter, Sound level adapter, Anemometer adapter, Light adapter, EMF adapter.

2. SPECIFICATIONS

2-1 General Specifications

Display	65 mm x 48 mm large LCD display with bar graph indicator.
Measurement	DCV, ACV, DCA, ACA, Resistance, Capacitance, Frequency, Duty, Diode, Continuity beeper.
A/D counts no.	4000 counts.
Range selection	Auto range with manual range selecting.
Special function	Relative measurement, Data hold.
Data hold	To freeze the display reading on the LCD display.
Power On/Off management	Auto power of or manual power off. <i>@ Details please refer page 8</i>
Relative measurement	To offset the measurement value.
Polarity	Automatic Switching, " - " indicates negative polarity.
Zero adjustment	Automatic.
Sampling time	Approx. 0.5 to 1 second.
Operating Temp. & humidity	0 to 50 °C (32 to 122 °F), Max. 80% RH.
Power supply	006 p dc 9V battery.
Power consumption	Approx. DC 1.7 mA.

Dimension	185 x 88 x 40 mm (7.3 x 3.5 x 1.6 inch)
Weight	350 g/0.77 LB.
Accessories Included	Red and Black Test Leads (CAT III 1KV Test Leads)..... 1 Set 0.5 Amp Spare Fuse..... 1 PC Instruction Manual..... 1 PC
Optional accessories	Full line adapters : ACA/DCA current adapter, Tachometer adapter, Humidity adapter, Pressure adapter, Light adapter, EMF adapter, Sound level adapter, High voltage probe.

2-2 Electrical Specifications (23± 5°C)

DC Voltage

Range	400.0 mV /4 V/40 V/400 V/1000 V
Resolution	0.1 mV /1 mV /10 mV /100m V/1 V
Accuracy	± (0.5%+2d)
Input impedance	10 M ohm.
Over load protection	± 500 DCV, 350 ACV - 400 mV range. ± 1000 DCV, 1000 ACV - other ranges.

AC Voltage (True RMS)

Range	4 V/40 V/400 V/1000 V
Resolution	1 mV /10 mV /100m V/1 V
Accuracy	$\pm (1\%+2d)$ <i>* Spec. are tested under 50/60 Hz.</i>
Input impedance	10 M ohm.
Over load protection	± 1000 DCV, 1000 ACV - other ranges.

AC Current (True RMS)**DC Current**

Range	10 A/400 mA/40 mA/4000 uA/400 uA
Resolution	10 mA/0.1 mA/0.01 mA/1 uA/0.1 uA
Accuracy	400 mA/40 mA/4000 uA/400 uA : $\pm (0.5\%+2d)$ 10 A : $\pm (1.5\%+2d)$ <i>* ACA spec. are tested under 50/60 Hz.</i>
Over load protection	10A range : 10A fuse. uA, mA range : 500 mA fuse.

Diode (Forward voltage, VF)

Range	4 V DC.
Resolution	0.001 V.
Accuracy	$\pm (0.5\%+2d)$

Capacitance

Range	40 nF/400 nF/4 uF/40 uF
Resolution	10 pF/0.1 nF/1 nF/10 nF
Accuracy	< 2 nF : $\pm (3\%+20d)$ Others : $\pm (3\%+1d)$

Frequency

Range	4 Hz/40 Hz/400 Hz/4 KHz/40 KHz/ 400 KHz/4 MHz
Resolution	0.001 Hz/0.01 Hz/0.1 Hz/0.001 KHz/0.01 KHz 0.1 KHz/0.001 MHz
Accuracy	$\pm (0.5\%+2d)$
Sensitivity	Min. 1.5 V rms, Max. 5 V rms.

Duty

Range	1 % to 99 %
Resolution	0.1 %
Accuracy	$\pm 1\%$ duty
Measuring signal and level	Function switch set to " Hz " : 2 Vp-p to 5 Vp-p, square wave 10 KHz max. Function switch set to "ACV", "ACA" : 50 Hz to 500 Hz

OHMS

Range	400/4 K/40 K/400 K/4 M/40 M ohm
Resolution	0.1/1/10/100/1 K/10 K ohm
Accuracy	400 ohm $\pm (0.5\%+2d)$ 4K/40K/400K/4 M 40 M $\pm (2\%+5d)$
Over load protection	± 500 DCV, 350 ACV

Continuity Beeper

Beeper will sound if measured resistance less than 20 ohm.

Remark :

* Spec. tested under the environment RF Field Strength less than 3 V/M & frequency less than the 30 MHz only.

3. FRONT PANEL DESCRIPTION

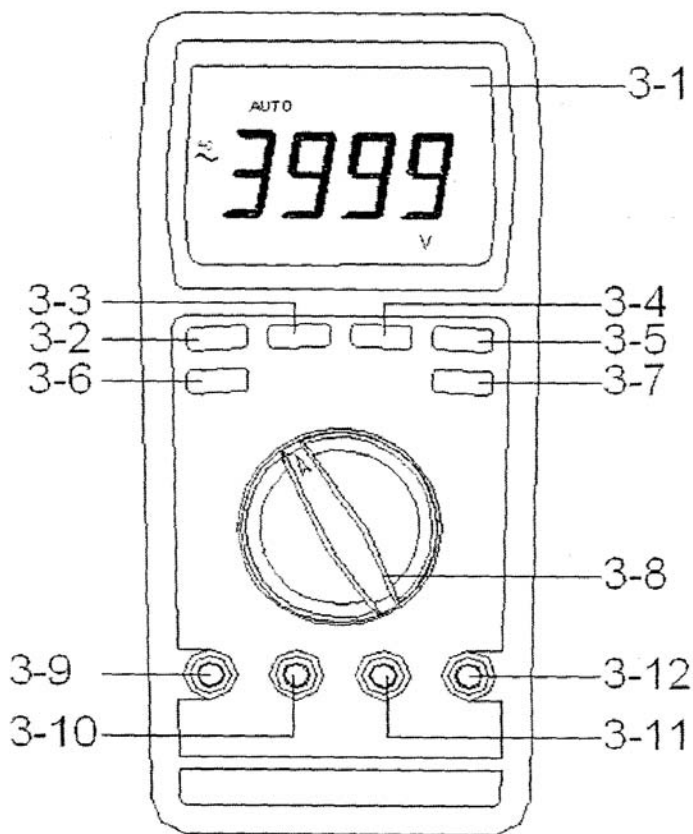

Fig. 1

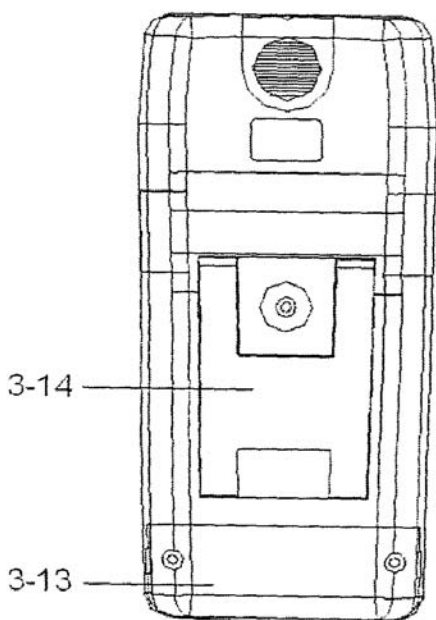

Fig. 1





- 3-1 Display
- 3-2 HOLD button
- 3-3 Hz/DUTY button
- 3-4 REL button
- 3-5 DCA/ACA button
- 3-6 RANGE button
- 3-7 Ohm/Diode/Buzzer button
- 3-8 Function rotary switch
- 3-9 10A input terminal
- 3-10 mA/uA input terminal
- 3-11 COM input terminal
- 3-12 Voltage/Ohm/Cap./Hz input terminal
- 3-13 Battery compartment/Cover
- 3-14 Stand

4. PRECAUTIONS & PREPARATIONS FOR MEASUREMENT

- 1) Ensure that the 006 DC 9V battery are connected with the right polarity and placed in the battery compartment correctly.
- 2) Place the Red & Black Test Leads into the proper input terminal before making measurement.
- 3) Remove either of the test leads from the circuit when changing the measurement range.
- 4) Except operate the " Data Hold " function, it should cancel the " Data Hold " function, otherwise the display reading will freeze permanently.
- 5) Do not exceed the maximum rated voltage and current to the input terminal.
- 6) Always switching the " Function Rotary Switch " to the " Off " position when the instrument is not operation.
- 7) Remove the battery if the instrument is not to be used in a long period of time.
- 8) For safety consideration, when change the new test leads, it should use the replace test leads that already approval of " CATIII-1000 V " at least.
- 9) Power On/Off management :
 - a. When not use the meter, should rotate the " Function rotary switch " (3-8, Fig. 1) to the " OFF " position.
 - b. During the measurement, after 30 minutes the meter will auto power off. If intend to power on again, it should rotate the " Function switch " to " OFF " position then set to the new desiring function position.

5. MEASURING PROCEDURE

5-1 Symbols & units of display

Symbols Units	Descriptions
AUTO	Appears when selecting " Automatic range " mode.
	Appears when selecting DC mode. (DC voltage or DC current)
	Appears when selecting AC mode. (AC voltage or AC current)
HOLD	Appears when the " Data hold " function is operated.
REL	Appears when the " Relative " function is operated.
	Battery voltage is already under the low condition.
	Appears when the " Continuity beeper " is operated.
mV, V	Units for voltage measurements.
uA, mA, A	Units for " Current " measurement.
Ω , K Ω , M Ω	Units for resistance measurements.
nF, uF	Units for " Capacitance " measurement.
Hz, KHz, MHz	Units for " Frequency " measurement.
%	Duty
	Appears when the " Diode " function is operated.
—	Appears when measuring a DCV or DCA value is negative.
OL	Over range indicator

5-2 DC Voltage, AC voltage Measurement

- 1) Connect BLACK test lead into " COM " terminal (3-11, Fig. 1).
- 2) Connect RED test lead into " V " terminal (3-12, Fig. 1).
- 3) a. Select the " Function rotary switch " (3-8, Fig. 1) to the " ACV " position for ACV measurement.
b. Select the " Function rotary switch " (3-8, Fig. 1) to the " DC V " position for DCV (4V/40V/400V/1000 V) measurement.
c. Select the " Function rotary switch " (3-8, Fig. 1) to the " DC mV " position for DC mV (400 DC mV, one range only) measurement.
- 4) When LCD show the " AUTO " marker, the meter is under the " auto range " mode. Meter will select the suitable measurement range automatically.
 - * Under the operation of " auto range " mode, push the " Range button " (3-6, Fig. 1) once will execute the " Manual Range " mode and hold the range, the " AUTO " marker will be disappeared.
 - * Under the manual range operation, push the " Range button " (3-6 Fig. 1) > 2 seconds, will return to auto range operation, the " AUTO " marker will present on the LCD again.

5-3 Resistance Measurement

- 1) Connect BLACK test lead into " COM " terminal (3-11, Fig. 1).
- 2) Connect RED test lead into " Ω " terminal (3-12, Fig. 1).
- 3) Select the " Function rotary switch " (3-8, Fig. 1) to the " Ω " position.

4) When LCD shows the " AUTO " marker, the meter is under the " auto range " mode. Meter will select the suitable measurement range automatically.

* Under the operation of " auto range " mode, push the " Range button " (3-6, Fig. 1) once will execute the " Manual Range " mode and hold the range, the " AUTO " marker will be disappeared.

* Under the manual range operation, push the " Range button " (3-6 Fig. 1) > 2 seconds, will return to auto range operation, the " AUTO " marker will present on the LCD again.

5-4 DC Current, AC Current Measurement

mA : 400 mA range, 40 mA range.

uA : 4000 uA range, 400 uA range.

1) Connect BLACK test lead into " COM " terminal (3-11, Fig. 1).

2) For the " mA, uA " measurement, connect RED test lead into " mA uA " terminal (3-10, Fig. 1).
For the " 10 A " current measurement, connect RED test lead into " A " terminal (3-9, Fig. 1).

Open the circuit in which current is to be measured. Now securely connect test leads in series with the load in which the current is to be measured.

- 3)a. For the " μA " measurement (400 μA , 4000 μA), select the " Function rotary switch " (3-8, Fig. 1) to " μA " position.
- b. For the " mA " measurement (40 mA, 400 mA), select the " Function rotary switch " (3-8, Fig. 1) to " mA " position.
- c. For the " 10 A " measurement, select the " Function rotary switch " (3-8, Fig. 1) to " A " position.
- 4) Push the " DCA/ACA button " (3-5, Fig. 1) to select the " ACA " or " DCA " measurement,
The ACA measurement display will show AC.
The DCA measurement display will show DC.
- 5) When LCD show the " AUTO " marker, the meter is under the " auto range " mode. Meter will select the suitable measurement range automatically.
- 6) When LCD show the " AUTO " marker, the meter is under the " auto range " mode. Meter will select the suitable measurement range automatically.
 - * Under the operation of " auto range " mode, push the " Range button " (3-6, Fig. 1) once will execute the " Manual Range " mode and hold the range, the " AUTO " marker will be disappeared.
 - * Under the manual range operation, push the " Range button " (3-6 Fig. 1) > 2 seconds, will return to auto range operation, the " AUTO " marker will present on the LCD again.

5-5 Continuity Check

- 1) Connect BLACK test lead into " COM " terminal (3-11, Fig. 1).
- 2) Connect RED test lead into " Ω " terminal (3-12, Fig. 1).
- 3) Select the " Function rotary switch " (3-8, Fig. 1) to the " Ω " position, push the " Ohm/Diode/Buzzer Button " (3-7, Fig. 1) for display show " Ω " .
- 4) when the resistance value is less than 20 ohm, the beeper sound will be generated.

5-6 Diode Test

- 1) Connect BLACK test lead into " COM " terminal (3-11, Fig. 1).
- 2) Connect RED test lead into " Ω " terminal (3-12, Fig. 1).
- 3) Select the " Function rotary switch " (3-8, Fig. 1) to " Ohm/Diode/Buzzer Button " (3-7, Fig. 1) for display show " \rightarrow " .
- 4) a. When connected with polarity as shown in Fig. 2, a forward current flow is established and the approx. Diode Forward Voltage (VF) value in volt will appears on the display reading. If the diode under test is defective, " .000 " or near " .000 " value (short circuit) or " .OL " (open circuit) will be displayed.

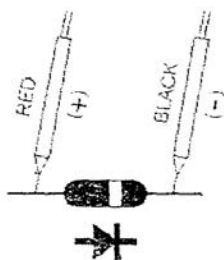

Fig. 2

- b. When connected as shown in Fig. 3, a reverse check on the diode is made. If the diode under test is good, ".OL " will be displayed. If the diode under test is defective, ".000 " or other numbers will be displayed. Proper diode testing should include both steps a. and b. above.

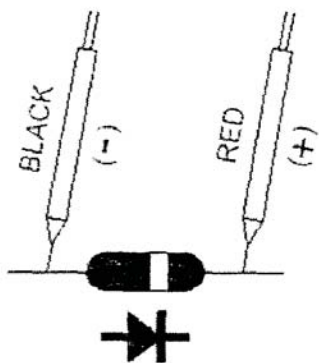

Fig. 3

5-7 Capacitance Measurement

- 1) Connect BLACK test lead into " COM " terminal (3-11, Fig. 1).
- 2) Connect RED test lead into " || " terminal (3-12, Fig. 1).
- 3) Select the " Function rotary switch " (3-8, Fig. 1) to the " || " position.

4) Zero adjustment :

Due to the consideration of the existing " stray capacitance " of the internal circuit board or the test alligators. For the 40 nF & 400 nF range, it should to make the zero adjustment procedures before make the measurement first. Open the input terminal & not connecting the measured capacitor, push the " REL. Button " (3-4, Fig. 1), the display will show zero value. Then connect the measuring capacitor again & make the measurement following.

- 5) For the capacitance measurement, the meter is always under the " auto range " mode., it will select the suitable measurement range automatically.

5-8 Frequency, Duty Measurement

Frequency

- 1) Connect BLACK test lead into " COM " terminal (3-11, Fig. 1).
- 2) Connect RED test lead into " V " terminal (3-12, Fig. 1).
- 3) Select the " Function rotary switch " (3-8, Fig. 1) to the " Hz " position then push the " Hz/DUTY Button " (3-3, Fig. 1) for display show " Hz " .
- 4) For the FREQUENCY measurement, the meter is always under the " auto range " mode, it will select the suitable measurement range automatically.

DUTY

All the measuring procedures are same as above Frequency measurement except push the " Hz/DUTY " (3-3, Fig. 1) for display show " % " .

Remark :

Under the ACV measurement (5-2) or ACA measurement (5-4), if push the " Hz/DUTY Button " (3-6, Fig. 1) once a while , will also can measure frequency value or DUTY value of the measured ACV or ACA.

5-9 Relative Measurement

- 1) During the measurement, the circuit will memorize the last measured values if push the " REL. Button " (3-4, Fig. 1) at once, then LCD will show zero value & a " REL " indicator.
- 2) The input measured values will deduct last measured values " automatically, then show those new value on the display.
- 3) It will cancel the relative measurement function if push the REL. button at once again, at same time the " REL " marker will disappear.

5-10 Data Hold Operation

- 1) During the measurement, pushing the " Hold button " (3-2, Fig. 1) once a while will freeze the measured value & the LCD will indicate " HOLD " symbol.
- 2) Push the " Hold Button " again to cancel the data hold function.

6. MAINTENANCE



Caution : *Remove test leads before opening the battery cover !*

6-1 Battery replacement

- 1) When the LCD display showing the mark of "  ", it is necessary to replace the battery, However in-spec. measurement may still be made for several hours after " Low battery indicator " appears before the instrument become inaccurate.
- 2) Open the screw of " Battery Cover " (3-13, Fig. 1) by loosening the screws, then move the battery.
- 3) Replace with DC 9V battery (006 P) and reinstate the cover.

6-2 Cleaning

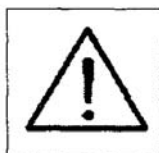

Caution : *Cleaning - Only use the dry cloth to clean the plastic case !*

6-3 Replacement of Fuse



Caution : *When make the replacement, should change the right spec. fuse.*

a. Fuse A -

Rating : 500 mA, Size : 5 mm dia. x 20 mm

To be protected the circuit from overload current at " 400 μ A, 4000 μ A, 40 mA, 400 mA " range. in other overload protection circuit).

b. Fuse B -

Rating : 10 A, Size : 6 mm dia. x 30 mm

To be protected the circuit from overload current at " 10 A " range.

- 1) When the μ A, mA current range can not operation, please check if the Fuse A is broken or not:
- 2) When the 10 A current range can not operation, please check if the Fuse B is broken or not:
- 3) When replace the fuse should take the test leads from the measuring circuit and power off the meter.
- 4) Take the screws away from the down case, loose the housing case, the fuses are install on the fuse socket on the PCB.
- 5) For safety consideration, when replace the fuse according the spec. (should use the approval fuse) and reinstall the cover.
- 6) Make sure the housing case is secured with the screw after replace the fuse.

7. OPTIONAL ACCESSORIES and ADAPTERS

<i>Item</i>	<i>Model</i>
<i>Carrying Case</i>	<i>CA-05A</i>
<i>Humidity Adapter</i>	<i>HA-702</i>
<i>Light Adapter</i>	<i>LX-02</i>
<i>EMF Adapter</i>	<i>EMF-824</i>
<i>Pressure Adapter</i>	<i>PS-403</i>
<i>Anemometer Adapter</i>	<i>AM-402</i>
<i>Tachometer Adapter</i>	<i>TA-601</i>
<i>Sound Adapter</i>	<i>SL-406</i>
<i>High Voltage Probe</i>	<i>HV-40</i>

8. THE ADDRESS OF AFTER SERVICE CENTER

