



ATH-1232

DC Power Supply

User's Manual

SAFETY PRECAUTIONS

These instruments fulfill the regulations of CE-LVD (EN-61010:2001) and CE-EMC (EN-55022:1998/+A1:2000; EN 55024:1998; EN61000-3-2:2000; EN61000-3-3:1995)

To ensure safe operation of the equipment and eliminate the danger of serious injury due to short-circuit (arcing), the following safety precautions must be observed.

Damages resulting from failure to observe these safety precautions are exempt from any legal claims whatever.

- * Prior to connection of the equipment to the mains outlet, check that the available mains voltage corresponds to the voltage setting of the equipment.
- * Connect the mains plug of the equipment only to a mains outlet with earth connection.
- * Do not place the equipment on damp or wet surfaces.
- * Do not subject the equipment to direct sunlight or extreme temperatures.
- * Do not subject the equipment to extreme humidity or dampness
- * Replace a defective fuse only with a fuse of the original rating. Never short circuit fuse or fuse housing
- * Do not exceed the maximum permissible input rating.
- * Conduct measuring works only in dry clothing and in rubber shoes, i.e. on isolating mats.
- * Comply with the warning labels and other info on the equipment.
- * Do not insert metal objects into the equipment by way of the ventilation slots
- * Do not place water-filled containers on the equipment (danger of short-circuit in case of knock over of the container)
- * Do not operate the equipment near strong magnetic fields (motors, transformer etc.)
- * Do not subject the equipment to shocks or strong vibrations
- * Keep hot soldering iron or guns away from the equipment
- * Allow the equipment to stabilize at room temperature before taking up measurement (important for exact measurement)
- * Do not modify the equipment in any way
- * Do not place the equipment face-down on any table or work bench to prevent damaging the controls at the front.
- * Opening the equipment and any service and repair work must be performed by qualified service personal. Repair work should be performed in the presence of a second person trained to administer first aid, if needed.
- * Power supplies do not belong to children hands.

CLEANING THE CABINET

Prior to cleaning the cabinet, withdraw the mains plug from the power outlet. Clean only with a damp, soft cloth and a commercially available mild household cleaner. Ensure that no water gets inside the equipment to prevent possible shorts and damage to the equipment.

The model ATH-1232 is high-precision DC regulated power supply, with its continuously adjustable voltage output. Constant voltage and constant current are switchable automatically, and the current-limit protection point can be set arbitrarily. In the constant current state, output current is continuously adjustable. The unit features in compact structure, plastic panel, good performance, novel appearance and etc, it is the ideal power supply unit for science investigation, college, factory, electronic appliance maintenance and etc.

ATH-1232 has LED for indication, constant voltage (with fine adjustable knob) and constant current.

Model	Voltage	Current	Size (WxHxD)	Weight (kg)
ATH-1232	0 ~ 30V	0 ~ 2A	240 x 108 x 154mm	4.5

1. TECHNICAL DATA

- 1.1 Input voltage: 110VAC~127VAC $\pm 10\%$ /60Hz
220VAC~240VAC $\pm 10\%$ /50Hz (SWITCHABLE)
- 1.2 Output voltage: See table
- 1.3 Output current: See table
- 1.4 Line regulation: CV $\leq 0.01\% + 3\text{mV}$
CC $\leq 0.2\% + 3\text{mA}$
- 1.5 Load regulation: CV $\leq 0.01\% + 2\text{mV}$
CC $\leq 0.2\% + 3\text{mA}$
- 1.6 Ripple and noise: CV $\leq 0.5\text{mV rms}$
CC $\leq 3\text{mA rms}$
- 1.7 Protection: Current-limit
- 1.8 Display accuracy:
 - a. Volt-indication: $\pm(0.2\%R_{\text{d}} + 2\text{ digits})$, $\pm 2.5\%$ Full Scale
 - b. Amp-indication: $\pm(1.0\%R_{\text{d}} + 2\text{ digits})$, $\pm 2.5\%$ Full Scale

2. OPERATION

2.2 Controls and description of front-panel

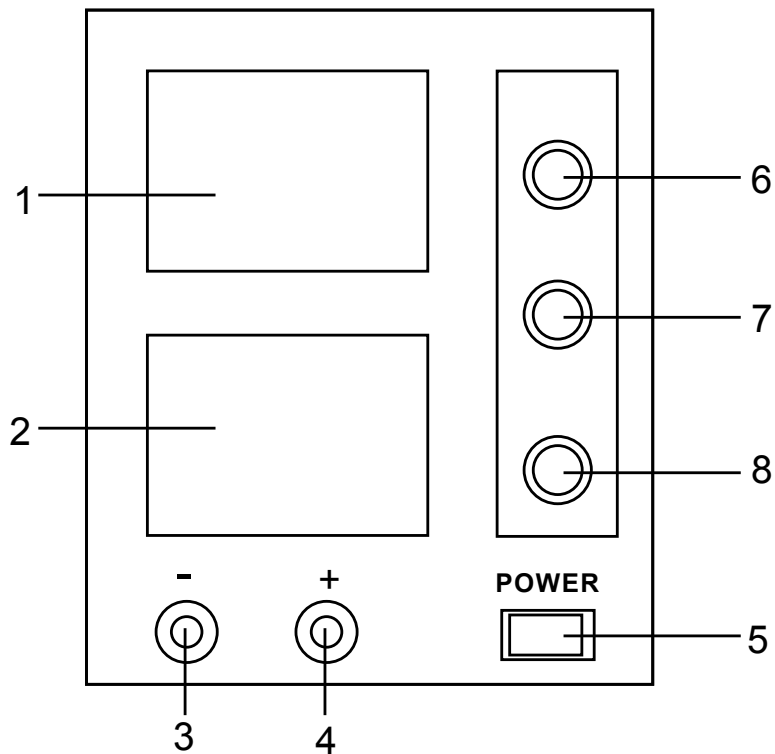

- (1) Volt display: indicating output voltage by analog meter, LCD or LED
- (2) Amp display: indicating output current by analog meter, LCD or LED
- (3) Output terminal (-): connecting the negative terminal of load
- (4) Output terminal (+): connecting the positive terminal of load
- (5) Power switch: the unit is "ON" when LED in this switch illuminating
- (6) Voltage coarse-adjustment: coarse-adjusting output voltage
- (7) Voltage fine-adjustment: fine-adjusting output voltage
- (8) Current adjustment: adjusting the current-limit protection point

2.2 Load connection:

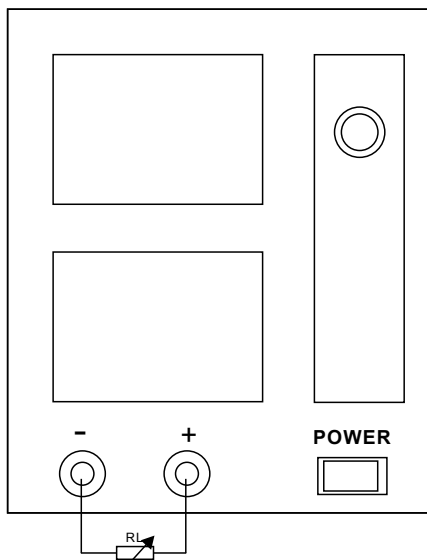

Load is connected as shown above. After the unit is switched on, output current will be indicated by LED , LCD or analog meter (2), and output voltage indicated by LED , LCD or analog meter (1). The unit may be overload or short-circuit. You should adjust the load to have the unit working properly.

2.3 To use the unit as constant-current source, when power switch on, turn the adjustments (6) and (7) clockwise to the end, and the (8) anti-clockwise to the end.

Then connect your load. Turn the current-adjustment (8) to get desired current.

2.4 As voltage regulated supply, the current- adjustment (8) must be set to their maximum values. At that time, you can set current-limit protection point arbitrarily. The setting procedure is: switch on power, connect a proper variable load and adjust its resistance to get current equal to protection point. Meanwhile, adjust current-adjustment (8) to maximum. So the current-limit point is set.

The LED(LCD)display is in three digits (analog meter is 2.5 class).

To get more accurate measuring value, you should calibrate by external circuit with precision measuring instrument.

3. CAUTIONS

- 3.1 This unit has excellent current-limit protection. If short-circuit occurs, the output current is limited. As there is controlling circuit for regulating transistor's power loss in the circuit, when short-circuit occurs, the power loss on large power transistors is not very high, it can't cause any damage to the unit. But there is still power loss when short-circuit, in order to reduce aging and energy consumption, so this situation should be found as soon as possible and turn off power, then exclude the faults.
- 3.2 When operating is finished, put it in a dry place of good ventilation, and keep it clean. If it is not in use for a long period, pull off the power supply plug for storage.
- 3.3 For maintenance, input voltage must be cut off.

4 ACCESSORIES

- 4.1 Instruction manual 1 copy
- 4.2 Fuse 2 pcs